

Assembly Instructions For N & TT-Scale Ford Model BB-157 1 ½ ton Truck



WARNING: CHOKING HAZARD
Keep out of reach of small children!

Note that these ARE NOT TOYS, AND ARE NOT INTENDED FOR USE BY CHILDREN UNDER AGE OF 14. These products are model railroad equipment and accessories intended for use by adults.

www.eaelec.com

Made in Canada

This is a scale model kit of the 1934 BB series truck. The BB series was in production from 1932 to 1934. It was equipped with either the standard four cylinder or the optional "flathead" V-8 (this kit depicts the V-8). The BB-157 indicates the longer wheelbase version (157") rather than the shorter wheelbase version (131.5"). The kit is available with several different cargo beds and loads, this first sheet of instructions is common and the second sheet is specific to the type of bed/load, such as stake bed with beer kegs of flat bed with lumber, etc..

Parts Included in the kit:

- A. 3D printed chassis.
- B. 3D printed cab
- C. 3D printed cargo bed
- E. 3D printed load - on some versions of the kit
- D. One decal sheet

Required to complete the kit:

- Paint - Flat black, silver, brown, wood, gloss coat
- and cab color (see painting guide on page 4) .
- Glue - Slow setting CA is best.

Tools Required:

- 1. X-acto knife with a sharp #11 blade.
- 2. #400 and #600 sandpaper.

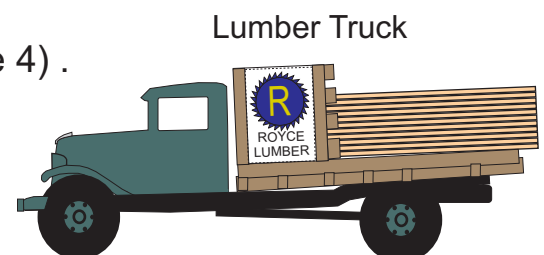

The 3D printing process requires a supporting frame during printing, see below left. The printed part is cut from the frame using flush cutters and this sometimes leaves small bumps on the part. Use a knife with a sharp new blade to cut away the bumps. When trimming bumps off the wheels you should place the wheel on a flat surface as shown below on the right. Putting too much stress on the wheel can cause the axle to break. For bumps on the cab body, sanding is recommended.

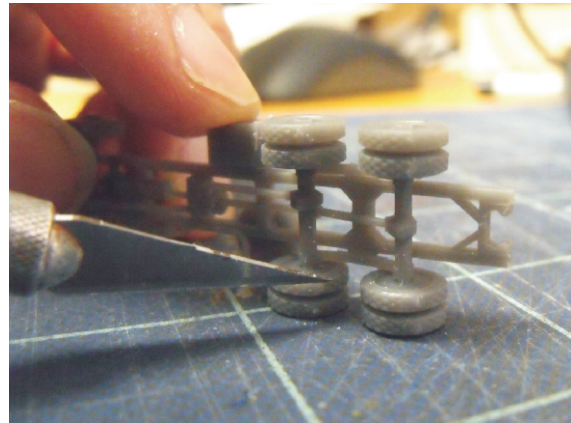
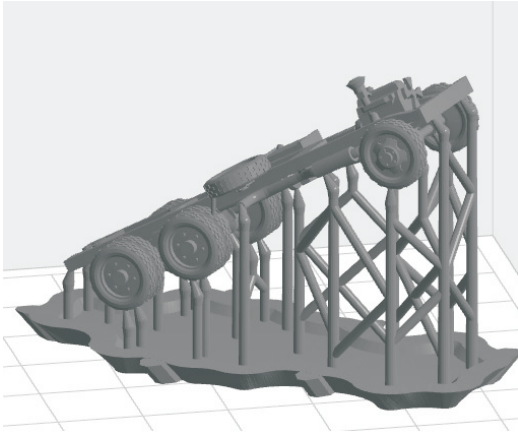

After cleaning up the bumps, paint the cab, cargo bed, chassis and the load as shown on the painting guide on page 4. The sign boards where the decals are placed should be painted with a gloss paint or clear gloss before the decals are applied. Decals don't set properly on a flat finish. Be sure to read the note on page 3 before applying decals. After the decals are completely dry, it is a good idea to apply a coat of gloss over the decals to preserve them.

When everything is dry, proceed to final assembly. Follow the steps below using CA glue.

Final Assembly - Step 1

Glue the cab to chassis.

When gluing the cab to chassis, the front of the grill should extend to red line

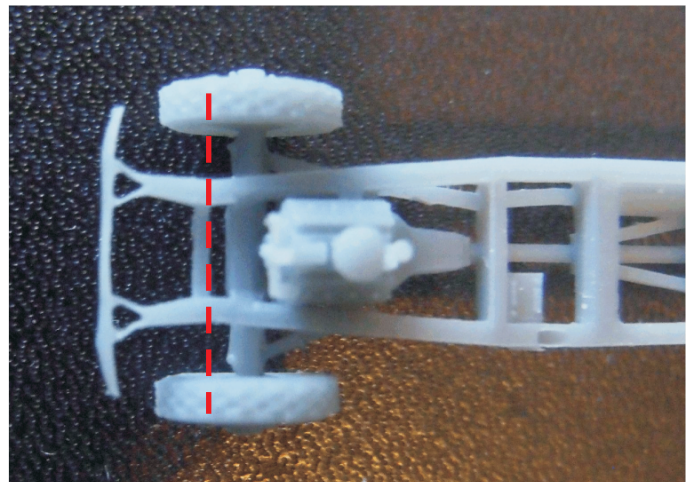
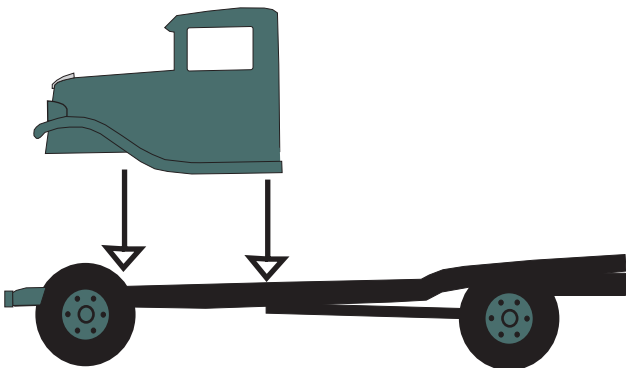

Final Assembly - Step 2

Glue the cargo bed to chassis.

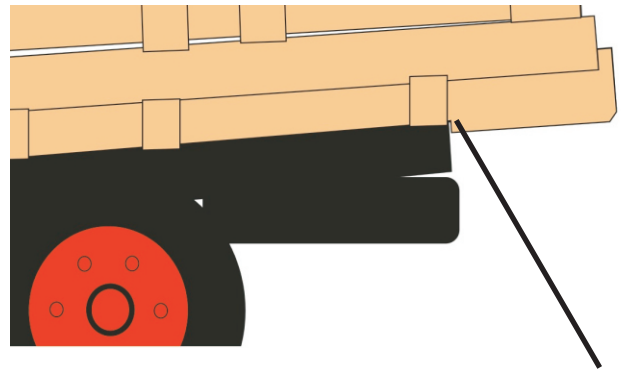
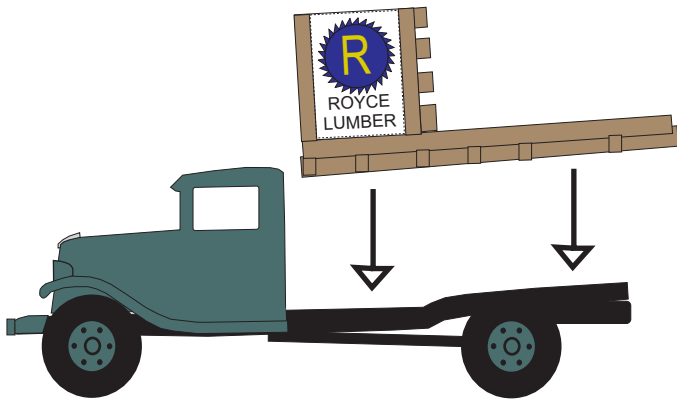

When gluing the cargo bed to chassis, this part of the bed hooks over the end of the chassis

Final Assembly - Step 3

Glue the lumber load to the cargo bed

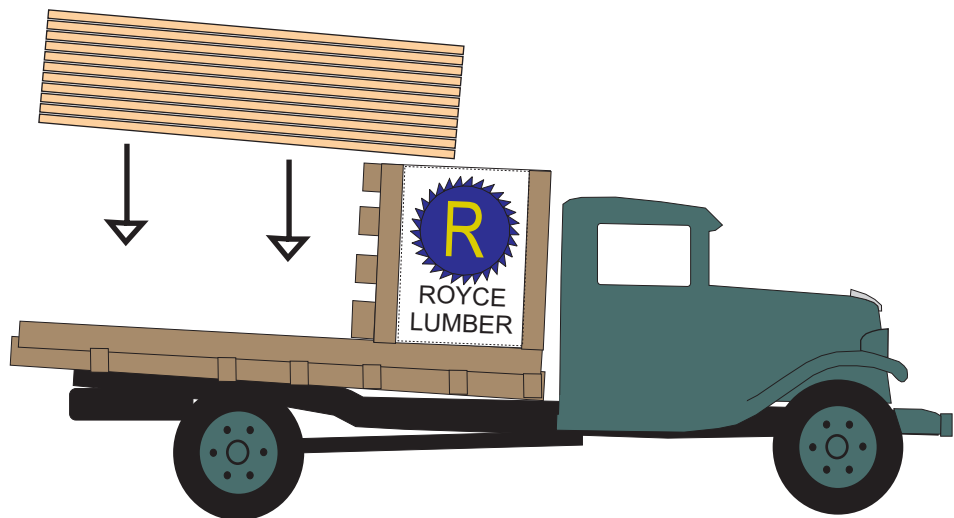

Note on Decals

Cut out decals on dotted lines:

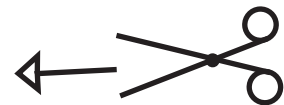
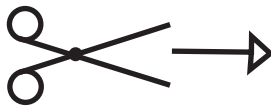

Ford BB-157 Truck Painting and Decal Placement

Left View

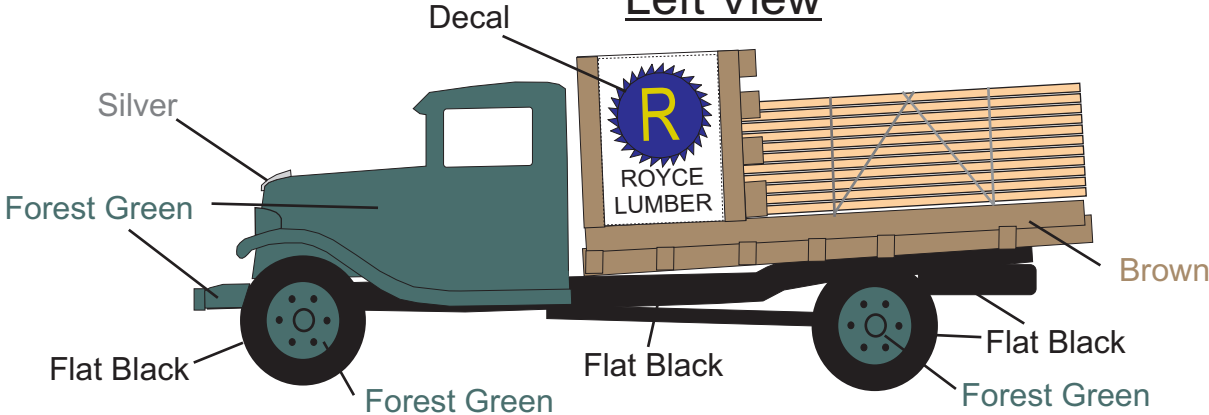

Right View

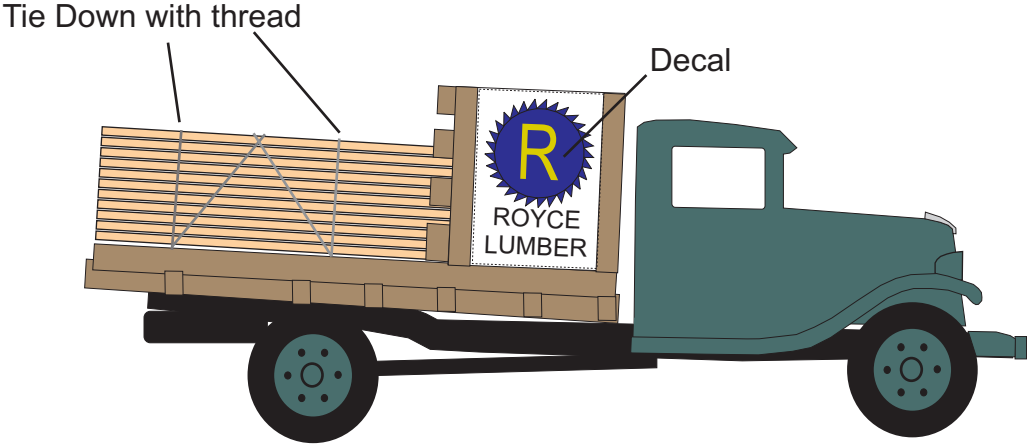

Front View

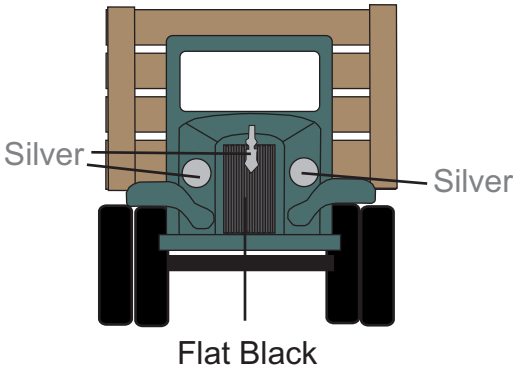

Lumber Load

