

Assembly Instructions For Z-Scale Power Wagon Tow Truck



www.eaelec.com
Made in Canada

The Dodge Power Wagon was mechanically derived from the WC series of 3/4 ton military trucks. Introduced in 1946 as the first post-war civilian production 4x4 truck; it featured an enclosed all-weather cab, an 8-foot cargo box, 126 inch wheelbase and a 230 cubic-inch flathead inline-six engine. This kit is the tow truck version of the Power Wagon.

A PDF version of this document can be downloaded from:

http://www.eaelec.com/ea_trains/zgauge_civ.htm

3D printed parts Included in the kit:

- A. chassis
- B. cab/tow bed

Also included:

- 1 photo-etched (PE) set
- 1 decal sheet
- 2 pieces of fine wire

Required to complete the kit:

- Paint - see painting guide
- Glue - CA and white canopy glue
- Tools - X-acto knife with sharp #11 blade, #400 and 600 sandpaper, flush cutters, pliers, tweezers and photo-etch shears

Photo-Etch Tools



WARNING: CHOKING HAZARD
Keep out of reach of small children!

Note that these ARE NOT TOYS, AND ARE NOT INTENDED FOR USE BY CHILDREN UNDER AGE OF 14. These products are model railroad equipment and accessories intended for use by adults.

3D Printed Parts in the Kit

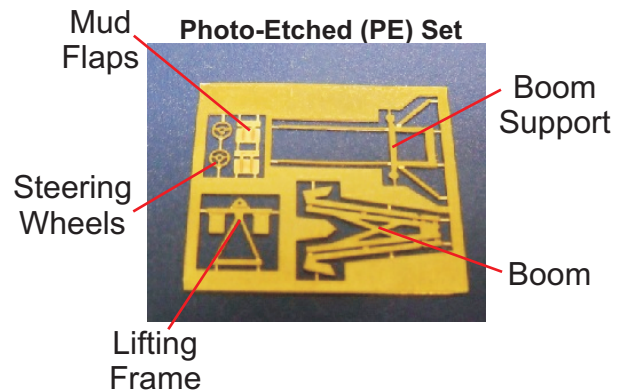
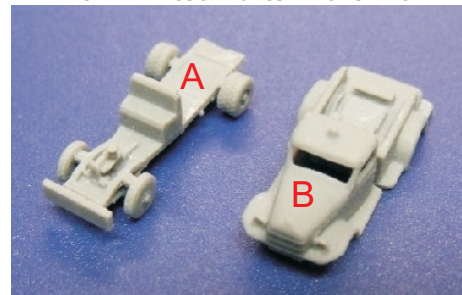

Decal Sheet

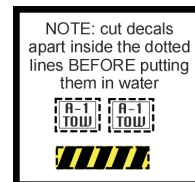

The 3D printing process requires a supporting frame during printing, see below. The printed part is cut from the frame using flush cutters and this sometimes leaves small bumps on the part. Use a knife with a sharp new blade to cut away the bumps. A flat jeweler's file is also useful for removing bumps. For bumps on the cab body, sanding is recommended.

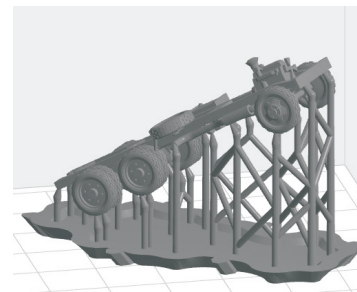

Preparing the Photo-etch for Painting

First I brush the PE set with vinegar (a mild acid). This will clean off any residue left on the brass and help the paint to adhere. Then I rinse with water and let the set dry thoroughly.

I recommend bending the boom part of the tow hoist to the final shape before painting. Most other parts can be painted while still attached to the fret. Carefully cut the boom from the PE fret and follow the steps below.

Bending the Boom



Step 1: grip the boom with pliers

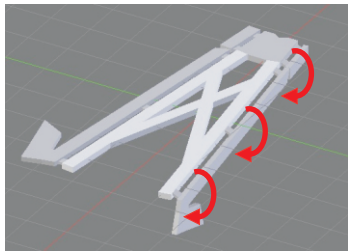

Step 2: bend the side down 90 degrees

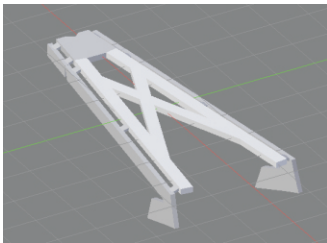

Repeat step 1 & 2 for the opposite side, the result should look like this

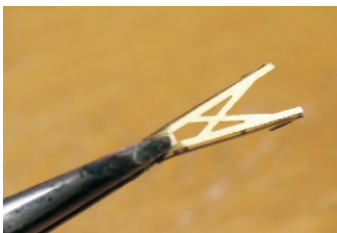

Step 3: grip the narrow end of the boom with tweezers



Step 4: bend the narrow end of the boom down as shown on left

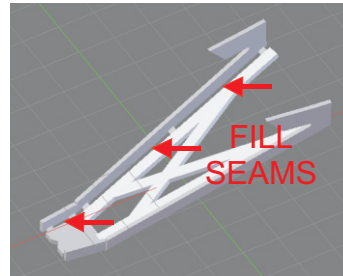

Step 5: turn the boom over and apply a 50/50 mixture of white glue diluted with water to fill the seams on both sides

Preparing The Lifting Frame

This tow truck features what is known as a "rubber and chain type lifting A-frame". Do not remove the lifting frame from the PE fret. Locate the 2 tabs which represent the rubber parts of the frame and bend them upwards as shown below.

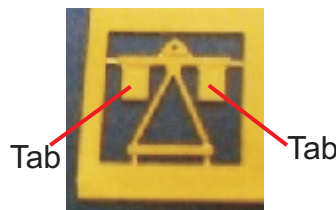

The Lifting Frame

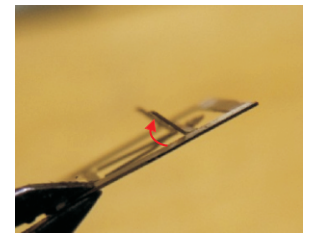

Bend Tabs Up

Apply a small drop of white glue to the bottom of each tab to give them some extra thickness.

The Mud Flaps

I find it easiest to attach the mud flaps to the tow bed before painting. Cut out the flaps, bend the short section over 90 degrees and glue them to the back of the wheel well using CA glue, as shown below.

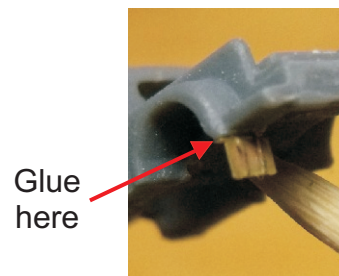

The Boom Support

There are 2 rear-facing spotlights on the boom support similar to the ones in the photo below on the left. Apply a small drop of white glue to round off the back of each light.

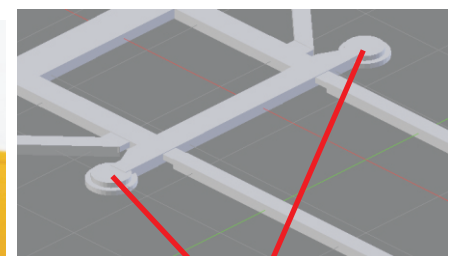

Apply Glue here

Painting The Tow Truck

Cab And Tow Bed

I painted the cab/bed silver using a spray can of acrylic laquer from an automotive supply store, then brush painted the details using enamels. Acrylics and enamels both work well on the 3D printed parts.

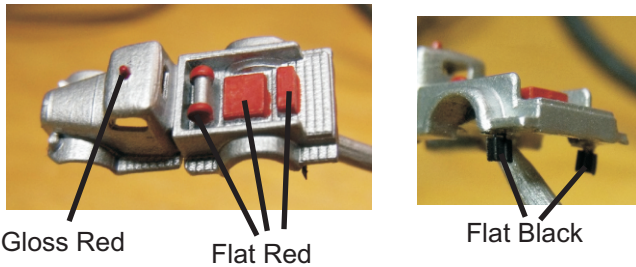

The Chassis

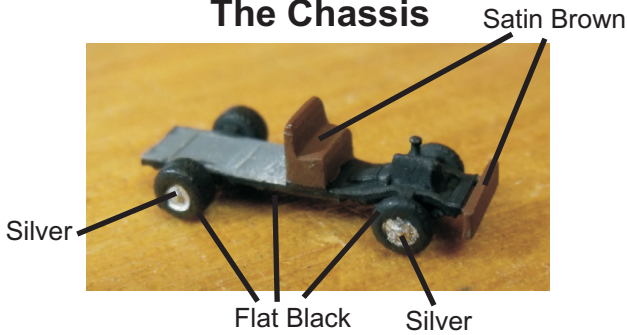
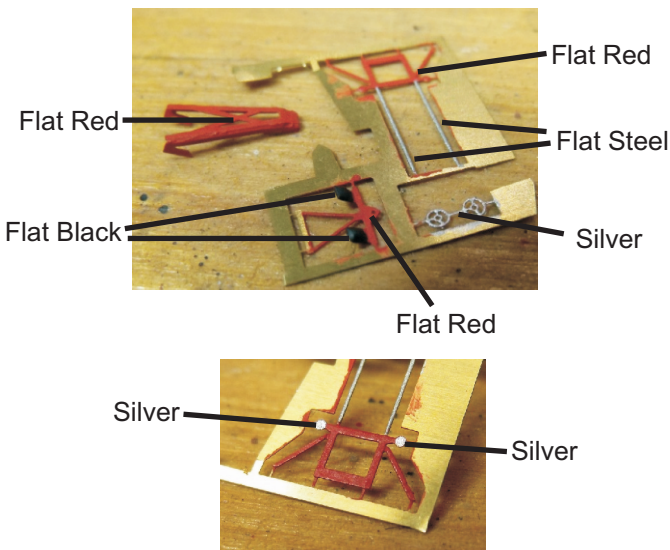

Photo-etched Parts

I find enamel paints adhere better than acrylics on PE. Note there are 2 steering wheels in the set, this is because they are so easy to lose!



The Decals

NOTE: Cut out decals just inside the dotted lines before soaking the in water. There are 3 decals, one for each door and one on the rear bumper. After the decals are dry I apply a light coat of clear gloss varnish to preserve them.

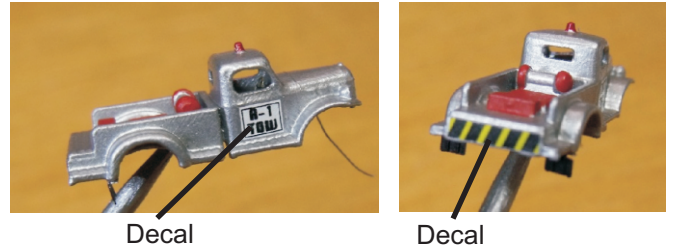

Assembly The Steering Wheel

Gluing the wire used for the steering column into the steering wheel and getting it aligned correctly is one of the most difficult parts of this build. I made a very simple jig simplify this operation. I cut 1/2 inch off the end of a new piece of 1/16" OD brass tubing. It is important to use the perfectly square factory-cut end for this jig. I closed off the end where I made the cut with a drop of CA glue (DO NOT close off the factory-cut end).

I mounted the piece of tubing in a block of wood to complete the jig, but you don't need to do this. Holding the tubing in place with a clamp will work.

I lay the wheel flat on the end of the tube, then poke the wire through the hole in the center of the wheel hub and push the wire through until it hits the blockage at the bottom of the tube. I apply a tiny drop of CA glue to the hub using the tip of a needle. After the glue is dry I pull it out and cut off the end of the wire that was in the tube with flush cutters.

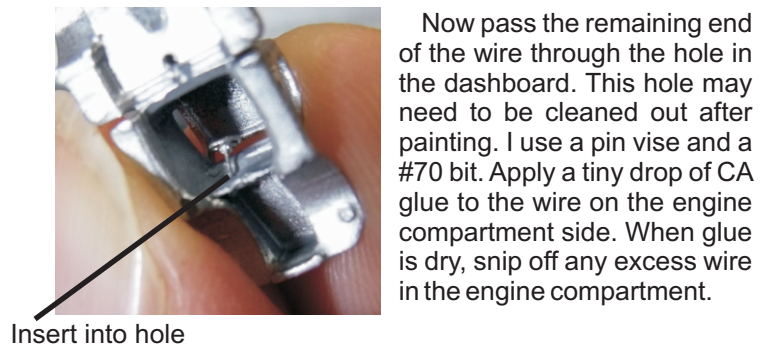
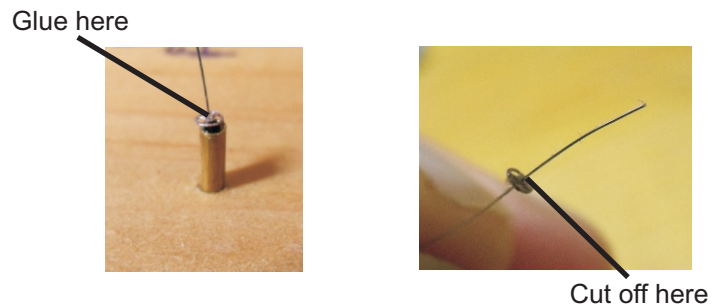

Now pass the remaining end of the wire through the hole in the dashboard. This hole may need to be cleaned out after painting. I use a pin vise and a #70 bit. Apply a tiny drop of CA glue to the wire on the engine compartment side. When glue is dry, snip off any excess wire in the engine compartment.

The Boom Support

Cut the boom support from the PE fret, then bend the 2 braces back 90 degrees as shown below.

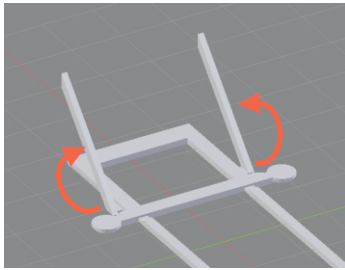

Now install boom support just behind the winch. Glue in place using CA glue as shown below. Leave the two boom support cables pointing up for now.

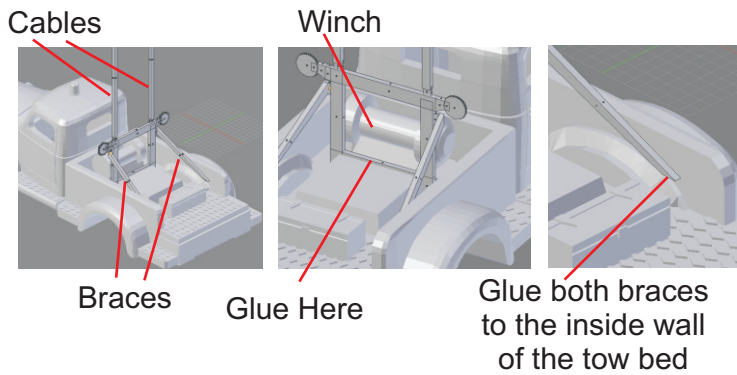

The Boom

Next install the boom as shown below using CA glue.

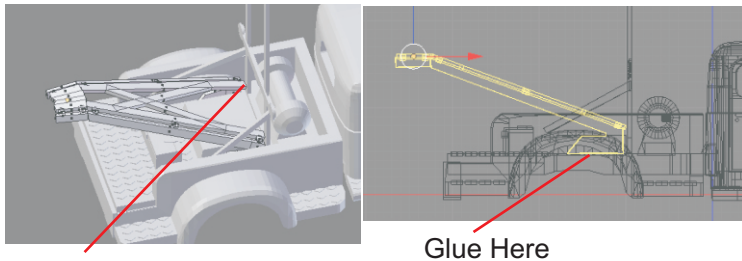

Now bend down the 2 boom support cables and glue to the top of the boom using CA glue.

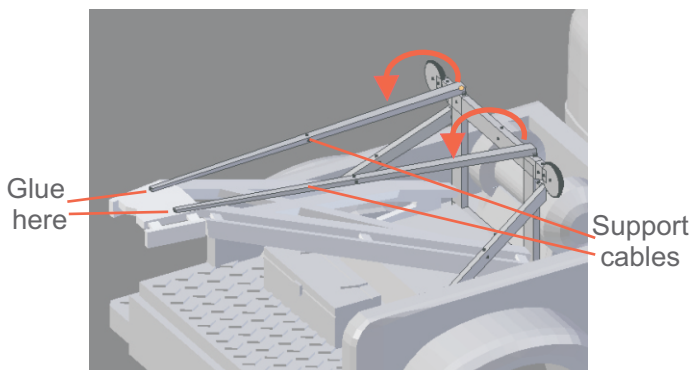

The Tow Line

Take one of 1 3/4 inch long pieces of wire included in the kit and make a 90 degree bend about 1/8 inch from the end. Insert the unbent end of the wire through the hole in the tow bed from the bottom. The wire should pass under the top bar of the support boom and between the support cables as shown. Apply glue to the wire in the hole from the bottom of the tow bed and let dry before proceeding. Then cut off any excess wire on the bottom.

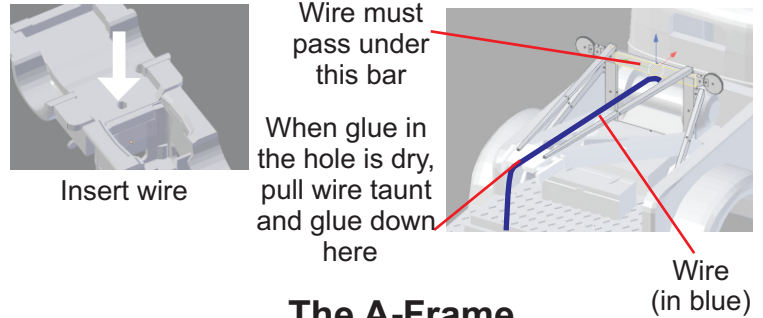

The A-Frame

Cut the A-frame from the PE fret.

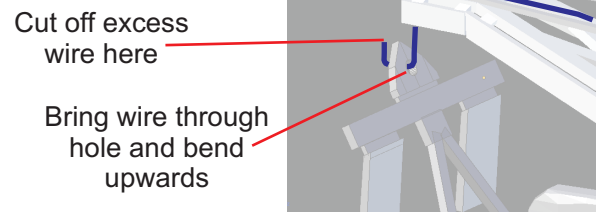
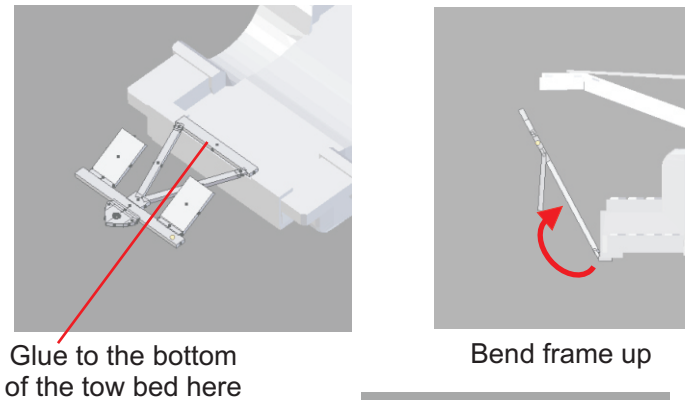

Glue cab/bed to chassis, model is finished.

